

# True RMS Multimeter

## User Manual



Large 50,000 count 320 x 240  
TFT color LCD display



Bluetooth PC interface for easy  
data transfer & accuracy  
calibration



IP67 Water and Dustproof

Please read this manual before switching the unit on.  
Important safety information inside.



# Contents

## True RMS Multimeter

|                               |       |
|-------------------------------|-------|
| 1. Introduction.....          | 4     |
| 2. Safety.....                | 4-5   |
| 3. Safety Instructions.....   | 5-6   |
| 4. Feature.....               | 7-9   |
| 5. Measurement and Setup..... | 10-29 |
| 6. General Specification..... | 30-31 |
| 7. Specifications.....        | 32-35 |

### 1.Introduction

Professional True RMS Industrial Digital Multimeter and TFT color LCD display, providing fast A/D converting sampling time, high accuracy , built-in datalogging and Trend Capture features. It can trace any interrupted problems of the equipments and watch on without person. It is easy to find and solve the problems of the production equipments, providing Bluetooth technology and memory the datasheets. It is much more safe measurements with double molded plastic housing design and IP67 waterproof function.

This meter measures AC/DC Voltage, AC/DC Current, 4-20mA %, Resistance, Capacitance, Frequency (electrical & electronic), Duty Cycle, Diode Test, Insulation Test, and Continuity plus Thermocouple Temperature. It can store and recall data. It features a waterproof, rugged design for heavy duty use. Proper use and care of this meter will provide many years of reliable service.

### 2.Safety



This symbol adjacent to another symbol, terminal or operating device indicates that the operator must refer to an explanation in the Operating Instructions to avoid personal injury or damage to the meter.

**WARNING** This **WARNING** symbol indicates a potentially hazardous situation, which if not avoided, could result in death or serious injury.

**CAUTION** This **CAUTION** symbol indicates a potentially hazardous situation, which if not avoided, may result damage to the product.



This symbol advises the user that the terminal(s) so marked must not be connected to a circuit point at which the voltage with respect to earth ground exceeds (in this case) 1000 VAC or VDC.



This symbol adjacent to one or more terminals identifies them as being associated with ranges that may, in normal use, be subjected to particularly hazardous voltages. For maximum safety, the meter and its test leads should not be handled when these terminals are energized.



This symbol indicates that a device is protected throughout by double insulation or reinforced insulation.

### **PER IEC1010 OVERVOLTAGE INSTALLATION CATEGORY OVERVOLTAGE CATEGORY I**

Equipment of OVERVOLTAGE CATEGORY I is equipment for connection to circuits in which measures are taken to limit the transient overvoltages to an appropriate low level.

**Note** – Examples include protected electronic circuits.

### **OVERVOLTAGE CATEGORY II**

Equipment of OVERVOLTAGE CATEGORY II is energy-consuming equipment to be supplied from the fixed installation.

**Note** – Examples include household, office, and laboratory appliances.

### **OVERVOLTAGE CATEGORY III**

Equipment of OVERVOLTAGE CATEGORY III is equipment in fixed installations.

**Note** – Examples include switches in the fixed installation and some equipment for industrial use with permanent connection to the fixed installation.

### **OVERVOLTAGE CATEGORY IV**

Equipment of OVERVOLTAGE CATEGORY IV is for use at the origin of the installation.

**Note** – Examples include electricity meters and primary over-current protection equipment

## **3. Safety Instructions**

This meter has been designed for safe use, but must be operated with caution.

The rules listed below must be carefully followed for safe operation.

**3-1. NEVER** apply voltage or current to the meter that exceeds the specified maximum:

| Input Protection Limits   |  |
|---|--|
| Function  | Maximum Input  |
| V DC or V AC  | 1000VDC/AC RMS   |
| mA AC/DC  | 800mA 1000V fast acting fuse   |
| A AC/DC   | 10A 1000V fast acting fuse<br>(20A for 30 seconds max every<br>15 minutes) |
| Frequency, Resistance, Capacitance,<br>Duty Cycle, Diode Test, Continuity | 1000VDC/AC rms   |
| Temperature   | 1000VDC/AC rms   |
| Surge Protection: 8kV peak per IEC 61010                                  |  |

- 3-2. USE EXTREME CAUTION** when working with high voltages.
- 3-3. DO NOT** measure voltage if the voltage on the “COM” input jack exceeds 1000V above earth ground.
- 3-4. NEVER** connect the meter leads across a voltage source while the function switch is in the current, resistance, or diode mode. Doing so can damage the meter.
- 3-5. ALWAYS** discharge filter capacitors in power supplies and disconnect the power when making resistance or diode tests.
- 3-6. ALWAYS** turn off the power and disconnect the test leads before opening the covers to replace the fuse or batteries.
- 3-7. NEVER** operate the meter unless the back cover and the battery and fuse covers are in place and fastened securely.

If the equipment is used in a manner not specified by the manufacturer, the protection provided by the equipment may be impaired.

## 4.Feature

### 4-1.Understanding the Push Buttons

The 12 push buttons on the front of the Meter activate features that augment the function selected using the rotary switch, navigate menus or control power to Meter circuits.

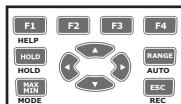

**F1F2F3F4** Selects sub-functions and modes related to the rotary switch function.

**Cursor buttons** select an item in a menu, adjust display contrast, scroll through information, and perform data entry.

**HOLD** Freezes the present reading in the display and allows the display to be saved. Also accesses AutoHold.

**RANGES** switches the Meter range mode to manual and then cycles through all ranges. To return to auto ranging, press the button for 1 second.

**MAX/MIN** Starts and stops MIN MAX recording.

**ESC** Return from Power off.

### 4-2.Understanding the Display

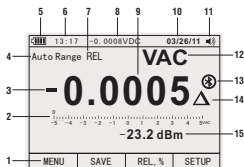

1. Soft key labels Indicates the function of the button just below the displayed label.
  2. Bar graph Analog display of the input signal (See the "Bar Graph" section for more information).
  3. Minus sign Indicates a negative reading.
  4. Indicates the range the Meter is in and the ranging mode (auto or manual)
  5. Battery level Indicates the charge level batteries.
  6. Time Indicates the time set in the internal clock.
  7. Mode annunciators Indicates the Meter's mode.
  8. Minimeasurement Displays the lightning bolt (when necessary) and the input value when the primary and secondary displays are covered by a menu or pop-up message.
  9. Main display Displays measurement information about the input signal.
  10. Date Indicates the date set in the internal clock.
  11. Beeper Indicates the Meter's beeper is enabled (not associated with the continuity beeper).
  12. Units Indicates the units of measure.
- N Auxiliary Units Indicates unit less measurements like Crest Factor.
13. Blue tooth Indicates activity over the communication link.
  14. Relative Indicates the displayed value is relative to a reference value.
  15. Secondary display Displays secondary measurement information about the input signal.

### 4-4. Page Area

The page area of the display is where the main meter content is displayed.

The primary display (upper half of the page area) is where the most important value of the selected function is shown. The secondary display contains the bar graph and values that may be measured in addition to the primary function value. For example, with frequency measurement selected in Vac, the frequency value will appear in the primary display with the ac voltage value in the secondary display.

### 4-5. Softkey Labels

Labels for the four function softkeys (F1 through F4) appear in the bottom row of the display. These labels will change based on the function and/or menu selection.



#### 4-6. Understanding the Rotary Switch

Select a primary measurement function by positioning the rotary switch to one of the icons around its perimeter. For each function, the Meter presents a standard display for that function (range, measurement units, and modifiers).



Button choices made in one function do not carry over into another function.

|  |   |
|--|---|
| <b>V<math>\overline{\sim}</math></b>     | DC (AC) and AC+DC voltage measurements<br>AC voltage measurements                           |
| <b>mV<math>\overline{\sim}</math></b>    | DC (AC) millivolts, ac+dc millivolt measurements  |
| <b>Hz%</b>                               | Frequency measurements  |
| <b>Ω<math>\overline{\sim}</math> CAP</b> | Resistance, Diode test, Capacitance and Continuity measurements<br>Temperature measurements |
| <b>4-20mA%</b>                           | %4 - 20mA MEASUREMENTS  |
| <b>A<math>\overline{\sim}</math></b>     | AC, DC and AC+DC amps measurements  |
| <b>mA<math>\overline{\sim}</math></b>    | AC, DC and AC+DC milliamps measurements   |
| <b>μA<math>\overline{\sim}</math></b>    | AC, DC and AC+DC microampere measurements up to 5,000μA                                     |

#### 4-7. Using the Input Terminals

All functions except current use the VOHMS and COM input terminals. The two current input terminals (A and mA/μA) are Used as follows:

Current from 0 to 500 mA, use the μmA and COM terminals.  
Current between 0 and 10 A use the A and COM terminals.

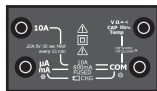

|                                 |   |
|---------------------------------|---|
| <b>10A</b>                      | Input for 0 A to 10.00 A current (20VA overload for 30 seconds on, 10 minutes off), |
| <b>μA<br/>mA</b>                | Input for 0 A to 500 mA current measurements.                                       |
| <b>COM</b>                      | Return terminal for all measurements.   |
| <b>V Ω<br/>Hz%<br/>CAP Temp</b> | Input for voltage, continuity, resistance, diode test, conductance, capacitance.    |

## 5. Measurement and Setup

### 5-1. DC Voltage Measurements

**CAUTION:** Do not measure DC voltages if a motor on the circuit is being switched ON or OFF. Large voltage surges may occur that can damage the meter.

1. Set the function switch to the green VDC position.
2. Insert the black test lead banana plug into the negative COM jack. Insert the red test lead banana plug into the positive V jack.
3. Read the voltage in the display.

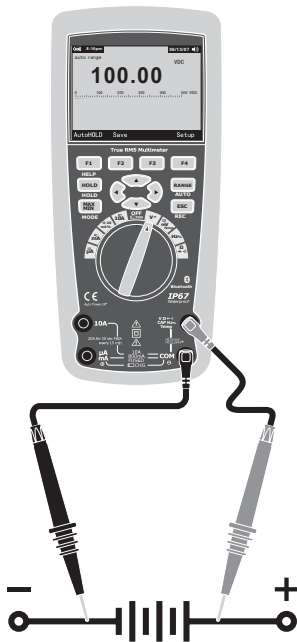

## 5-2.AC Voltage Measurements

**WARNING:** Risk of Electrocution. The probe tips may not be long enough to contact the live parts inside some 240V outlets for appliances because the contacts are recessed deep in the outlets. As a result, the reading may show 0 volts when the outlet actually has voltage on it. Make sure the probe tips are touching the metal contacts inside the outlet before assuming that no voltage is present.

**CAUTION:** Do not measure AC voltages if a motor on the circuit is being switched ON or OFF. Large voltage surges may occur that can damage the meter.

1. Set the function switch to the green VAC position.
2. press the soft key labeled Menu. Move the menu selector to the menu item labeled VAC. Press the soft key VAC
3. Insert the black test lead banana plug into the negative COM jack. Insert red test lead banana plug into the positive V jack.
4. Read the voltage in the main display

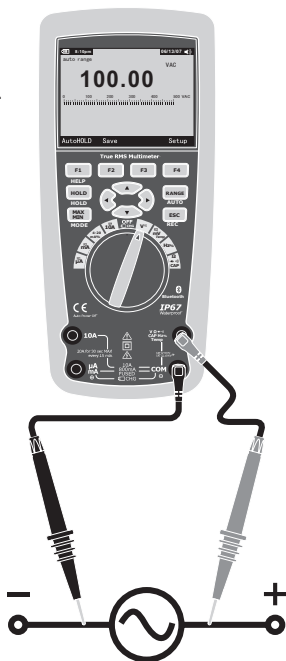

## 5-3. Making dB Measurements

The Meter is capable of displaying voltage as a dB value, either relative to 1 milliwatt (dBm), a reference voltage of 1 volt (dBV) or a user-selectable reference value.

1. Set the function switch to the green VAC position.
2. Press the softkey labeled Menu. Move the menu selector to the menu item labeled dBm. Press the softkey dBm.
3. Insert the black test lead banana plug into the negative COM jack. Insert red test lead banana plug into the positive V jack.
4. Read the voltage in the main display and the dBm in the Secondary display.
5. To select another reference value, press the softkey labeled Ref to display a message box with the current reference value. Pressing ▲ or ▼, scrolls through the nine predefined references: 4, 8, 16, 25, 32, 50, 75, 600 and 1000. Set the reference by pressing the softkey labeled OK.



## 5-4. Low Pass Filter

The Meter is equipped with an ac low pass filter. When measuring ac voltage, press the soft key labeled Menu to open the function menu, and move the menu selector to the LO item. Next, press the softkey labeled LO to toggle the low pass filter mode.



### 5-5.mV Voltage Measurements

**CAUTION:** Do not measure mV voltages if a motor on the circuit is being switched ON or OFF. Large voltage surges may occur that can damage the meter.

1. Set the function switch to the green mV position.
2. Press the soft key labeled Menu.  
Move the menu selector to the menu item labeled mVDC(mVAC). Press the soft key mVDC(mVAC).
3. Insert the black test lead banana plug into the negative COM jack. Insert the red test lead banana plug into the positive V jack.
4. Read the mV voltage in the display

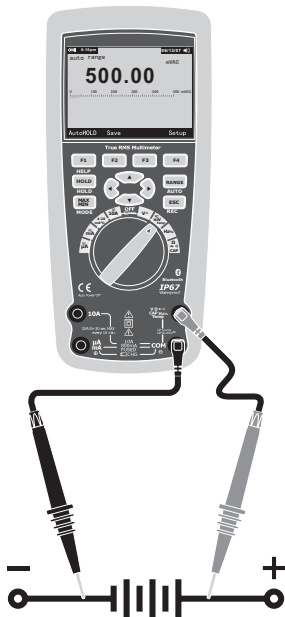

## 5-6. Temperature Measurements

1. Set the function switch to the green TEMP (°C or °F) position.
2. Press the soft key labeled Menu. Move the menu selector to the menu item labeled TEMP. Press the soft key TEMP (°C or °F).
3. Insert the Temperature Probe into the input jacks, making sure to observe the correct polarity.
4. Read the temperature in the display.
5. To input a temperature offset value, press the softkey labeled Offset to open a message box with the present offset value. Use ◀ and ▶ to position the cursor over one of the digits or the polarity sign. Use ▲ and ▼ to scroll through the numbers for each digit in the offset or switch between a + or – offset. With the desired value displayed, press the softkey labeled OK to set the temperature offset.



## 5-7. Frequency Measurements

1. Set the function switch to the green Hz% position.
2. Insert the black test lead banana plug into the negative COM jack. Insert the red test lead banana plug into the positive V jack.
3. Read the Frequency in the display.

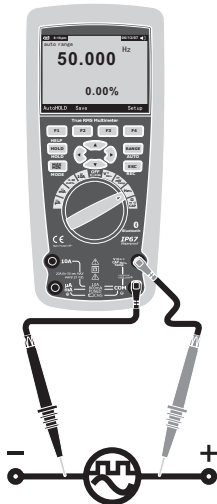

## 5-8. Resistance Measurements

**WARNING:** To avoid electric shock, disconnect power to the unit under test and discharge all capacitors before taking any resistance measurements.

Remove the batteries and unplug the line cords.

1. Set the function switch to the green  $\Omega$  CAP  $\rightarrow$   $\rightarrow$  position.
2. Insert the black test lead banana plug into the negative COM jack. Insert the red test lead banana plug into the positive  $\Omega$  Jack.
3. Read the resistance in the display.

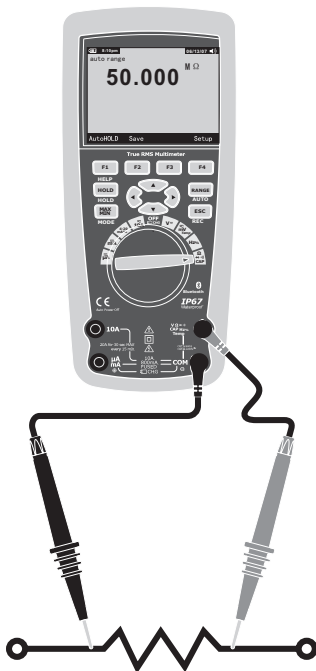

### 5-9. Continuity Check

**WARNING:** To avoid electric shock, disconnect power to the unit under test and discharge all capacitors before taking any resistance measurements. Remove the batteries and unplug the line cords.

1. Set the function switch to the green  $\Omega$  CAP  $\rightarrow$   $\rightarrow$  position.
2. Press the soft key labeled Menu. Move the menu selector to the menu item labeled Beeper. Press the soft key Beeper.
3. Insert the black test lead banana plug into the negative COM jack. Insert the red test lead banana plug into the positive jack.
4. If the resistance is less than approximately  $25\Omega$ , the audible signal will sound. If the circuit is open, the display will indicate "OL".

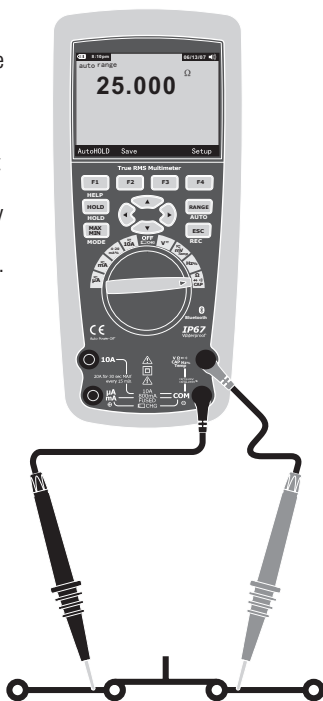



### 5-10. Diode Test

1. Set the function switch to the green  $\Omega$  CAP  $\rightarrow$   $\rightarrow$  position.
2. Press the soft key labeled Menu. Move the menu selector to the menu item labeled Diode. Press the soft key Diode.
3. Insert the black test lead banana plug into the negative COM jack and the red test lead banana plug into the positive V jack.
5. Forward voltage will typically indicate 0.400 to 3.200V. Reverse voltage will indicate "OL". Shorted devices will indicate near 0V and an open device will indicate "OL" in both polarities.

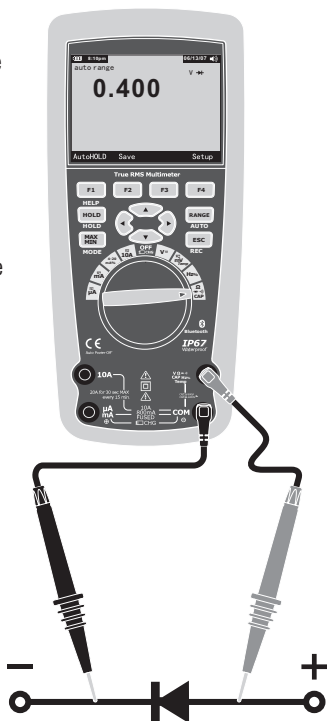

### 5-11. Capacitance Measurements

**WARNING:** To avoid electric shock, disconnect power to the unit under test and discharge all capacitors before taking any capacitance measurements. Remove the batteries and unplug the line cords.

1. Set the rotary function switch to the green  $\Omega$  CAP  $\rightarrow$   $\rightarrow$  position.
2. Press the soft key labeled Menu. Move the menu selector to the menu item labeled Cap. Press the soft key Cap.
3. Insert the black test lead banana plug into the negative COM jack. Insert the red test lead banana plug into the positive V jack.
4. Read the capacitance value in the Display

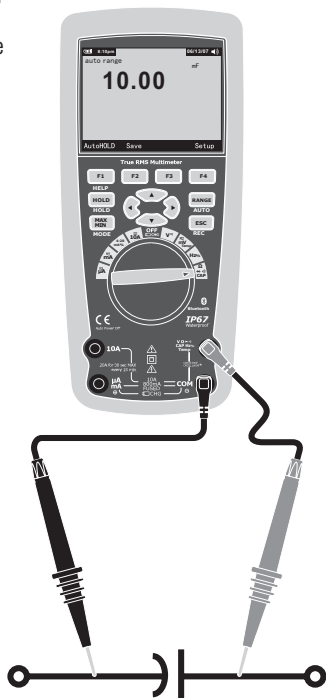

## 5-12.DC Current Measurements

**CAUTION:** Do not make 20A current measurements for longer than 30 seconds. Exceeding 30 seconds may cause damage to the meter and/or the test leads.

1. Insert the black test lead banana plug into the negative COM jack.
2. For current measurements up to  $5000\mu\text{A}$  DC, set the function switch to the yellow  $\mu\text{A}$  position and insert the red test lead banana plug into the  $\mu\text{A}/\text{mA}$  jack.
3. For current measurements up to  $500\text{mA}$  DC, set the function switch to the yellow  $\text{mA}$  position and insert the red test lead banana plug into the  $\mu\text{A}/\text{mA}$  jack.
4. For current measurements up to  $10\text{A}$  DC, set the function switch to the yellow  $10\text{A}$  position and insert the red test lead banana plug into the  $10\text{A}$  jack.
5. Press the MODE button to indicate “DC” on the display.
6. Read the current in the display.

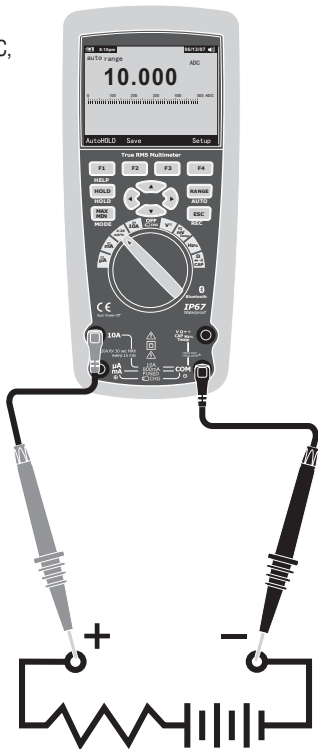

### 5-13.AC Current Measurements

**CAUTION:** Do not make 10A current measurements for longer than 30 seconds. Exceeding 30 seconds may cause damage to the meter and/or the test leads.

1. Insert the black test lead banana plug into the negative COM jack.
2. For current measurements up to  $5000\mu\text{A AC}$ , set the function switch to the yellow  $\mu\text{A}$  position and insert the red test lead banana plug into the  $\mu\text{A}/\text{mA}$  jack.
3. For current measurements up to  $500\text{mA AC}$ , set the function switch to the yellow  $\text{mA}$  position and insert the red test lead banana plug into the  $\mu\text{A}/\text{mA}$  jack.
4. For current measurements up to  $20\text{A AC}$ , set the function switch to the yellow  $10\text{A}$  position and insert the red test lead banana plug into the  $10\text{A}$  jack.
5. Press the soft key labeled Menu. Move the menu selector to the menu item labeled AC. Press the soft key AC.
6. Read the current in the display

### 5-14. %4-20mA MEASUREMENTS

1. Set the rotary function switch to the 4-20mA% position.
2. Insert the black test lead banana plug into the negative COM jack. Insert the red test lead banana plug into the positive  $\mu\text{A}/\text{mA}$  jack.
3. The meter will display loop current as a % with  $0\text{mA} = -25\%$ ,  $4\text{mA} = 0\%$ ,  $20\text{mA} = 100\%$ , and  $24\text{mA} = 125\%$ .

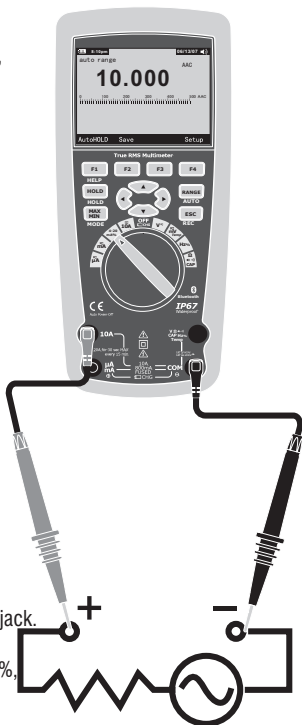

### 5-15. Understanding Function Menus

Each primary measurement function (rotary switch position) has a number of optional sub-functions or modes accessed by pressing the softkey labeled Menu (F1). A typical menu is shown in Figure.

Menu selection is indicated by the filled-in black square (hereafter the menu selector) to the left of a menu item. Use the four front-panel cursor buttons (▲▼◀▶) to position the menu selector next to a menu item. As the menu selector moves between menu items, the four softkeys and their labels change to reflect the available functions and/or modes available for the selection menu item.

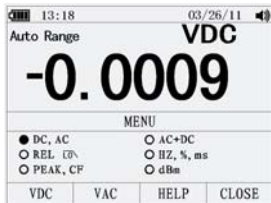

### 5-16. Using Help

While operating the Meter, more information about a selected function, a front-panel button, or a menu item may be necessary. Press soft key HELP to open an information window that lists topics covering the functions and modifiers that are available at the time the button is pressed. Each topic provides a brief explanation on a Meter function or feature. The number of information topics displayed at any one time may exceed the display area. Use the softkeys labeled Next and Prev to move from topic to topic. Use the softkey labeled More or ▲ and ▼ to scroll through the information a full screen at a time.

### 5-17. Measuring AC and DC Signals

The Meter is capable of displaying both AC and DC signal components (voltage or current) as two separate readings or one AC+DC(RMS) value combined. As shown in Figure , the Meter displays ac and dc combinations two ways: DC displayed over AC (DC,AC), and AC combined with dc (AC+DC). Select one of these three displays using the Function and Mode menu. With the rotary switch set to V, mV, A, mA, or  $\mu$ A, press the soft key labeled Menu. Move the menu selector to the menu item labeled AC+DC. At this point, three different soft key labels indicate AC+DC (F1), and DC, AC (F2). Press the soft key that presents these two signals as needed. While in any of the three AC+DC modes, peak measurements, frequency, duty cycle, relative %, and period measurements are not allowed. In addition to these modes, MIN MAX, relative.



### 5-18. Capturing Minimum and Maximum Values

The MAX MIN Record mode captures minimum, average, and maximum input values. When the input goes below the recorded minimum value or above the recorded maximum value, the Meter beeps and records the new value. The Meter stores the elapsed time since the recording session was started at the same time. The MAX MIN mode also calculates an average of all readings taken since the MAX MIN mode was activated. This mode is for capturing intermittent readings, recording minimum and maximum readings unattended, or recording readings while equipment operation precludes watching the Meter. The MIN MAX mode is best for recording power supply surges, inrush currents, and finding intermittent failures. Response time is the length of time an input must stay at a new value to be captured as a possible new minimum or maximum value.

To activate the MAX MIN mode, press MAX MIN. As shown in Figure, the Meter displays  $e$  at the top of the measurement page, and the MAX MIN start date and time along the bottom of the page. In addition, the recorded maximum, average, and minimum values appear in the secondary display with their respective elapsed times.

To stop a MIN MAX recording session, press the softkey labeled Stop. The summary information in the display freezes, and the softkeys change function to allow saving the collected data. Pressing the softkey labeled Close exits the MIN MAX record session without saving the collected data.



To save the MIN MAX screen data, the MIN MAX session must be ended by pressing the softkey labeled Stop. Next, press the softkey labeled Save. A dialog box opens where the default saved name can be selected or another name assigned. The softkey labeled Save to store. Pressing the softkey labeled Restart while MIN MAX is running stops the MIN MAX session, discards all MIN MAX data, and immediately starts a new MIN MAX recording session.

### 5-19. Capturing Peak Values

To activate the peak mode, press the softkey labeled Menu. Move the menu selector next to the menu item labeled Peak, CF or Peak. Press the softkey labeled Peak to start the peak recording session.



### 5-20. Relative Values

To activate the peak mode, press the softkey labeled Menu. Move the menu selector next to the menu item labeled REL or Peak. Press the softkey labeled REL to start the peak recording session. If the Meter is already in the relative function, pressing REL% causes the Meter to turn off relative and display relative percent.

### 5-21. Low Pass Filter

The Meter is equipped with an ac low pass filter. When measuring AC voltage, press the softkey labeled Menu to open the function menu, and move the menu selector to the LO item. Next, press the softkey labeled LO to toggle the low pass filter mode.



### 5-22. Hold and AutoHold Mode

To freeze the display for any function, press key HOLD.

Pressing the softkey labeled AutoHOLD activates AutoHold if the Meter is not in the Peak, MIN MAX, or Record modes. AutoHold operation monitors the input signal and updates the display and, if enabled, sounds the beeper, whenever a new stable measurement is detected. A stable measurement is one that does not vary more than a selected adjustable percentage (AutoHold threshold) for at least one second. The Meter filters out open lead conditions so the Meter leads can be moved between testpoints without triggering a display update.

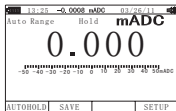

### 5-23. Storing Individual Measurement Data

For all measurement functions, a snapshot of the screen data is saved by pressing the softkey labeled Save.

Edit name, then pressing the softkey labeled Save stored date.





## 5-24. Viewing Memory Data

Viewing data stored in the Meter's memory is performed through the save menu. Press the softkey labeled Save. Position the menu selector next to the menu item labeled View measure and press the softkey labeled View.

If there are previously stored records, press the softkey labeled Prev to page back through previously stored records. Press the softkey labeled Next to page in the other direction. Press the softkey labeled Delete to delete stored records. Press Close to return to normal Meter operation.

## 5-25. Viewing Trend Data

Viewing data stored in the Meter's memory is performed through the save menu. Press the softkey labeled Save. Position the menu selector next to the menu item labeled View record and press the softkey labeled View. If there are previously stored records, press the softkey labeled Prev to page back through previously stored records. Press the softkey labeled Next to page in the other direction. Press Close to return to normal Meter operation.

Press the soft key labeled Trend to display the recorded data in a trend-plot view.

Press the softkey labeled Delete recorded data

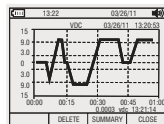

## 5-26. Recording Measurement Data

The Meter's record feature collects measurement information over a user-specified duration. This collection of information is called a recording session. A recording session is made up of one or more measurement records. Each record contains measurement summary information covering the duration of the record.

Press the softkey labeled Save. Position the menu selector next to the menu item labeled Record and press the softkey labeled Record to open the configuration display.







Recording session duration, and sample interval duration. Both variables affect the recording length and number of intervals recorded. These two variables may interact, in that setting one variable may adjust the other variable to fit the recording session within the available memory. The percentage of memory available at the beginning of a recording session is displayed below the duration and sample interval settings.

To change either of the two recording variables, use the cursor buttons to position the menu Selector next to the desired menu item and press the softkey labeled Edit. Use ▲▼◀ and ▶ to move between and set each digit of the selected variable.

Press the softkey labeled Start to start records.

The recording session will continue until the allocated memory is used, the batteries expire, the rotary switch is moved. or the session is terminated by pressing the softkey labeled Stop.

### 5.27. Zooming in on Trend Data

While viewing trend data, pressing  or  zooms in or out respectively on the data around the cursor. Each press of  reduces the x-axis time period by one half to reveal more details. Each press of  doubles the time period until all the recorded data is displayed. The zoom level is displayed in the upper-right hand corner of the display.

### 5-28. Changing Meter Setup Options

The Meter has a number of preset features such as date and time formats and battery save mode timeouts, and the displayed language. These variables are referred to as Meter setup options. Many setup options affect general Meter operations and are active in all functions. Others are limited to one function or group of functions.

Access to the setup options is always available through the softkey labeled Setup. Information about the Meter, such as serial number, model, for example. is also accessed through the setup menu.



### 5-29. Resetting Meter Setup Options

The Meter's setup options can be reset to default values through the setup menu. Open the setup menu by pressing the softkey labeled Setup. Position the menu selector next to the menu item labeled Reset and press the softkey labeled Setup. A message will appear asking to confirm the reset action. Press the softkey labeled OK to perform the reset.

### 5-30. Meter Info

The Meter Info selection lists the serial number, model number, firmware version, calibration date, and calibration counter. Operator name, company name are displayed.

### 5-31. Setting the Event Threshold Value

Press the softkey labeled Setup to access the setup menu.

Using the cursor buttons, move the menu selector next to the menu item labeled Instrument and press the softkey labeled Enter to open the recording setup screen. Using the cursor buttons, move the menu selector next to the menu item labeled Event Threshold for Recording (AutoHOLD) and then press the softkey labeled Edit. Press ▲ or ▼ to scroll through the event threshold values. With the desired value selected, press the softkey labeled Close.

### 5-32. Calibration

The Calibration selection allows a qualified calibration technician to enter a password that allows the Meter to be calibrated.

Press the softkey labeled Setup to access the setup menu. Using the cursor buttons, move the menu selector next to the menu item labeled Calibration and press the softkey labeled Calibrate. Then input password, Enter Calibration menu. If change password, Press the softkey labeled Setup to access the setup menu. Using the cursor buttons, move the menu selector next to the menu item labeled Calibration and press the softkey labeled password, Then input current password, Then input new password.

### 5-33. Using Communications

You can use the Wireless communication link and transfer the contents of a meter's memory to a PC.

Press the softkey labeled Setup to access the setup menu. Using the cursor buttons, move the menu selector next to the menu item labeled communicate and press the softkey labeled **ENTER**. Press the softkey labeled **OK** will start communications function.

### 5-34. Setting Date and Time

The Meter's internal clock is used in the display and for timestamping recorded measurements. To change the date and time as well as the display format, press the softkey labeled Setup. Position the menu selector next to the menu item labeled Display. To set the date and time, press the softkey labeled Date/Time to open the date/time menu. Next, position the menu selector next to either the Set Date item or Set Time item and press the softkey labeled Edit. Using ◀ and ▶, position the cursor on the date or time element to adjust. Use ▲ and ▼ to change the selected date or time element value. Press OK to complete the action.

### 5-35. Auto Power Off

Press the softkey labeled Setup. Position the menu selector next to the menu item labeled Display. To set Auto Power Off and then press the softkey labeled Edit. Use ▲ and ▼ to adjust the time to one of the preset values. 0 is disable the timeout feature. Press the softkey labeled OK to set the selected time. Press the softkey labeled Close to return.

### 5-36. Setting Format

Press the softkey labeled Setup. Position the menu selector next to the menu item labeled Format. Using the cursor buttons, move the menu selector next to the menu item labeled Numeric(Date\Time) format, press the softkey labeled EDIT, select 0.0000 (0,0000) and MM/DD/YY (DD/MM/YY) and 24 HOUR (12 HOUR) format.

### 5-37. Replacing the Batteries

Refer to Figure and replace the batteries as follows:

1. Turn the Meter off and remove the test leads from the terminals.
2. Remove the battery door assembly by using a standard blade screwdriver to turn the battery door screw one-half turn counterclockwise.
3. Replace the batteries with 7.4 volt charge batteries. Observe proper polarity.
4. Reinstall the battery door assembly and secure it by turning the screw one-half turn clockwise.

### 5-38.Replacing the Fuses

Referring to Figure , examine or replace the Meter's fuses as follows:

- 1.Turn the Meter off and remove the test leads from the terminals.
- 2.Remove the battery door assembly by using a standardblade screwdriver to turn the battery door screw one-half turn counterclockwise.
- 3.Remove the fuse by gently prying one end loose, then sliding the fuse out of its bracket.
- 4.Install only specified replacement fuses.
- 5.Reinstall the battery door assembly and secure it by turning the screw one-half turn clockwise.

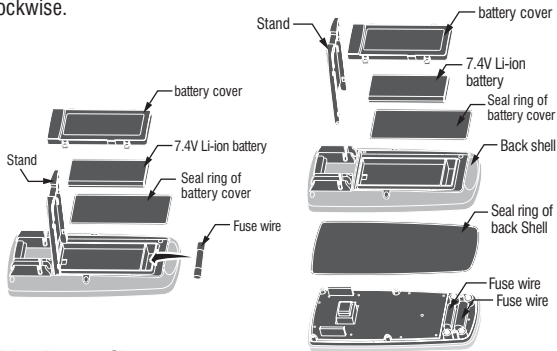

### 5-39.Li-ion Battery Charge

- 1.Set the function switch to the OFF/CHG position.
- 2.Insert the socket into the Meter Input port. And the Adapter connected to the switch socket. Then Insert the Adapter into Power socket.
- 3.Display charge symbol in TFT color LCD display.

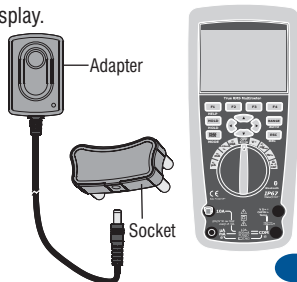

## 6. General Specification

|                        |  |
|------------------------|--|
| Enclosure              | Double molded, waterproof  |
| Shock (Drop Test)      | 6.5 feet (2 meters)  |
| Diode Test             | Test current of 0.9mA maximum, open circuit voltage 3.2V DC typical  |
| Continuity Check       | Audible signal will sound if the resistance is less than 25Ω (approx.), test current <0.35mA   |
| PEAK                   | Captures peaks >1ms  |
| Temperature Sensor     | Requires type K thermocouple   |
| Input Impedance        | >10MΩ VDC & >9MΩ VAC   |
| AC Response            | True RMS   |
| AC True RMS            | The term stands for “Root-Mean-Square” which represents the method of calculation of the voltage or current value. Average responding multimeters are calibrated to read correctly only on sine waves and they will read inaccurately on non-sine wave or distorted signals. True rms meters read accurately on either type of signal. |
| ACV Bandwidth          | 50Hz to 100000Hz   |
| Crest Factor           | ≤3 at full scale up to 500V, decreasing linearly to ≤1.5 at 1000V  |
| Display                | 50,000 count backlit liquid crystal with bargraph  |
| Overrange indication   | “OL” is displayed  |
| Auto Power Off         | 5-30minutes (approximately) with disable feature   |
| Polarity               | Automatic (no indication for positive); Minus (-) sign for negative  |
| Measurement Rate       | 20 times per second  |
| Low Battery Indication | “  ” is displayed if battery voltage drops below operating voltage  |

|                         |  |
|-------------------------|--|
| Fuses                   | Fuses are FF 0. 8A/1000V+FF 10A/1000V  |
| Operating Temperatur    | 5°C to 40°C (41°F to 104°F)  |
| Storage Temperature     | -20°C to 60°C (-4°F to 140°F)  |
| Operating Humidity      | Max 80% up to 31°C (87°F) decreasing linearly to 50% at 40°C (104°F)   |
| Storage Humidity        | <80%   |
| Operating Altitude      | 7000ft. (2000meters) maximum.  |
| Safety                  | This meter is intended for origin of installation use and protected, against the users, by double insulation per EN61010-1 and IEC61010-1 2nd Edition (2001)to Category IV 600V and Category III 1000V; Pollution Degree 2. The meter also meets UL 61010-1, 2nd Edition (2004), CAN/CSA C22.2 No. 61010-1 2nd Edition (2004),and UL 61010B -2-031, 1st Edition (2003) |
| Bluetooth specification | Version 2.0+EDR,Frequency range 2400 MHz ... 2483.5 MHz.(ISM-Band),Guard band 2 MHz < F < 3.5 MHz.Modulation method GFSK,1 Mbps,0.5 Gaussian; Receiving signal range -82 to -20 dBm; Transmission power Minimum: -18dBm to +4 dBm Diameter: 20.0mm; High 3.2mm; Typical Weight   |
| Built-in lithium        | 3.0 grams (0.10 oz.); Designation: ANSI / NEDA-5004LC,IEC-CR2032; Normal Voltage: 3.0 Volts; Typical Capacity: 240 mAh ; Storage 5 Year Chemical type: Lithium polymer,Standard: GB/T  |
| Li-ion Battery          | 18287-2000; Normal Voltage: 7.4 Volts; Charge up Voltage: 8.4 Volts; Typical Capacity: 2400 mAh. Cycle life: 500 times ;   |

## 7. Specifications

| Function<br>DC Voltage | Range                | Resolution | Accuracy           |
|------------------------|----------------------|------------|--------------------|
|                        | 50mV <sup>[1]</sup>  | 0.001mV    | (0.05% + 20)       |
|                        | 500mV <sup>[1]</sup> | 0.01mV     | (0.025% + 5digits) |
|                        | 5V                   | 0.0001V    | (0.025% + 5digits) |
|                        | 50V                  | 0.001V     | (0.025% + 5digits) |
|                        | 500V                 | 0.01V      | (0.05% + 5digits)  |
|                        | 1000V                | 0.1V       | (0.1% + 5)         |

[1] When using the relative mode (REL Q) to compensate for offsets.

| Function  | Range | Resolution | Accuracy           |
|---|-------|------------|--------------------|
| AC Voltage  |       |            | 50 to 10000Hz      |
|   | 50mV  | 0.001mV    | 50/60Hz(0.3% + 25) |
|   | 500mV | 0.01mV     | <1KHz(0.5% + 25)   |
|   | 5V    | 0.0001V    | <5KHz(3% + 25)     |
|   | 50V   | 0.001V     |                    |
|   | 500V  | 0.01V      |                    |
|   | 1000V | 0.1V       |                    |
| All AC voltage ranges are specified from 5% of range to 100% of range |       |            |                    |

| Function | Range | Resolution             | Accuracy          |
|----------|-------|------------------------|-------------------|
| (AC+DC)  |       |                        | 0 to 1000Hz       |
|          | 50mV  | 0.001mV                |                   |
|          | 500mV | 0.01mV                 | <1KHZ(1% + 25)    |
|          | 5V    | 0.0001V <sup>[1]</sup> | <10KHZ(3.5% + 25) |
|          | 50V   | 0.001V                 |                   |
|          | 500V  | 0.01V                  |                   |
|          | 1000V | 0.1V                   |                   |

[1] Add 1% above 5k



| Function   | Range                                   | Resolution   | Accuracy   |
|------------|---|--------------|------------|
| DC Current | 500 $\mu$ A                             | 0.01 $\mu$ A | 0.1% + 20  |
|            | 5000 $\mu$ A                            | 0.1 $\mu$ A  |            |
|            | 50mA                                    | 0.001mA      |            |
|            | 500mA                                   | 0.01mA       | 0.15% + 20 |
|            | 10A                                     | 0.001A       | 0.3% + 20  |
|            | (20A: 30 sec max with reduced accuracy) |              |            |

| Function  | Range                                   | Resolution   | Accuracy           |
|---|---|--------------|--------------------|
| AC Current  |   |              | 50 to 10000Hz      |
|   | 500 $\mu$ A                             | 0.01 $\mu$ A | 50/60Hz(0.6% + 25) |
|   | 5000 $\mu$ A                            | 0.1 $\mu$ A  |                    |
|   | 50mA                                    | 0.001mA      |                    |
|   | 500mA                                   | 0.01mA       | <1KHz(1.5% + 25)   |
|   | 10A                                     | 0.001A       | <10KHz(3% + 25)    |
|   | (20A: 30 sec max with reduced accuracy) |              |                    |
| All AC current ranges are specified from 5% of range to 100% of range |   |              |                    |

| Function  | Range        | Resolution   | Accuracy    |
|-----------|--------------|--------------|-------------|
| (AC + DC) |              |              | 0 to 1000Hz |
|           | 500 $\mu$ A  | 0.01 $\mu$ A | (1.0% + 25) |
|           | 5000 $\mu$ A | 0.1 $\mu$ A  |             |
|           | 50mA         | 0.001mA      |             |
|           | 500mA        | 0.01mA       |             |
|           | 10A          | 0.001A       |             |
|           |              |              | (1.5% + 40) |

| Function                    | Range | Resolution | Accuracy    |
|-----------------------------|-------|------------|-------------|
| AC Voltage<br>(5000+ Count) |       |            | 5K-100K     |
|                             | 50mV  | 0.001mV    | (5.0% + 40) |
|                             | 500mV | 0.01mV     |             |
|                             | 5V    | 0.0001V    |             |
|                             | 50V   | 0.001V     | (6.0% + 40) |

**NOTE:** Accuracy is stated at 18 to 28°C (65 to 83°F) and less than 75%RH. AC switch according to the calibration of sine wave. It generally increase  $\pm(2\%$  reading + 2% full scale) if non sine wave in the wave crest less than 3.0.

| Function   | Range                       | Resolution       | Accuracy |
|------------|-----------------------------|------------------|----------|
| Resistance | 50 $\Omega$ <sup>[1]</sup>  | 0.001 $\Omega$   | 0.5%+20  |
|            | 500 $\Omega$ <sup>[1]</sup> | 0.01 $\Omega$    | 0.05%+10 |
|            | 5k $\Omega$                 | 0.0001k $\Omega$ | 0.05%+10 |
|            | 50k $\Omega$                | 0.001k $\Omega$  |          |
|            | 500k $\Omega$               | 0.01k $\Omega$   | 0.1%+10  |
|            | 5M $\Omega$                 | 0.0001M $\Omega$ | 0.2%+20  |
|            | 50M $\Omega$                | 0.001M $\Omega$  | 2%+20    |

[1] When using the relative mode (REL Q) to compensate for offsets.

| Function    | Range               | Resolution    | Accuracy                       |
|-------------|---------------------|---------------|--------------------------------|
| Capacitance | 5nF <sup>[1]</sup>  | 0.001nF       | $\pm(2\% + 40)$                |
|             | 50nF <sup>[1]</sup> | 0.01nF        |                                |
|             | 500nF               | 0.1nF         | $\pm(2\% + 40 \text{ digits})$ |
|             | 5 $\mu$ F           | 0.001 $\mu$ F |                                |
|             | 50 $\mu$ F          | 0.01 $\mu$ F  |                                |
|             | 500 $\mu$ F         | 0.1 $\mu$ F   | $\pm(5\% + 40 \text{ digits})$ |
|             | 10mF                | 0.01mF        |                                |

[1] with a film capacitor or better ,using relative mode (REL  $\Delta$ ) to zero residual.

| Function  | Range               | Resolution      | Accuracy                     |
|---|---------------------|-----------------|------------------------------|
| Frequency<br>(electronic)   | 50Hz                | 0.001Hz         | $\pm(0.01\% + 10)$           |
|   | 500Hz               | 0.01Hz          |                              |
|   | 5kHz                | 0.0001kHz       |                              |
|   | 50kHz               | 0.001kHz        |                              |
|   | 500kHz              | 0.01kHz         |                              |
|   | 5MHz                | 0.0001MHz       |                              |
|   | 10MHz               | 0.001MHz        |                              |
| Sensitivity: 0.8V RMS min. @ 20% to 80% duty cycle and <100kHz; 5V RMS min @ 20% to 80% duty cycle and >100kHz. |                     |                 |                              |
| Frequency<br>(electrical)   | 40.00-10kHz         | 0.01 - 0.001kHz | $\pm(0.5\% \text{ reading})$ |
|   | Sensitivity: 1V RMS |                 |                              |

| Function   | Range  | Resolution | Accuracy                                      |
|------------|--|------------|---|
| Duty Cycle | 0.1 to 99.90%  | 0.01%      | $\pm(1.2\% \text{ reading} + 2\text{digits})$ |
|            | Pulse width: 100 $\mu$ s - 100ms, Frequency: 5Hz to 150kHz |            |   |
| 4-20mA%    | -25 to 125%  | 0.01%      | $\pm 50 \text{ digits}$                       |
|            | 0mA=-25%, 4mA=0%, 20mA=100%, 24mA=125%                     |            |   |

| Function         | Range         | Resolution | Accuracy  |
|------------------|---------------|------------|---|
| Temp<br>(type-K) | -50 to 1000°C | 0.1°C      | $\pm(1.0\% \text{ reading} + 2.5^\circ\text{C})$                                  |
|                  | -58 to 1832°F | 0.1°F      | $\pm(1.0\% \text{ reading} + 4.5^\circ\text{F})$<br>(Probe accuracy not included) |



**Rev.120630**